

HO MODULE HANDBOOK



FIRST EDITION

MAY 25, 2007

	MODULAR LAYOUT SYSTEM SPECIFICATIONS DIVISION 4, MID CENTRAL REGION, NMRA	DATA SHEET	DIV4-1.1		
		PAGE	1	OF	3
		REVISION	0		
		DATE	May 25, 2007		

Specifications

Date: May 25, 2007
 Revision: 0A
 Reference: NMRA Standards and Recommended Practices, MS-1.0, MRP-1, MS-1.3, MRP-1.3, S9

Purpose: To establish a uniform
 Module Size: Straight Module - 24" x 48" (not including width of fascia board, 1/8" and backboard, 1/2")
 Module depth may be increased to 30" max. Corner Module dimensions as shown in section (2). Return Loop Module dimensions as shown in section (3).

Module Sets: Module "sets" may be constructed using combinations of modules that are multiples of 48", i.e. 2 - 48" modules, 2 - 72" modules, etc. The only requirement is that the track centerlines, track ends, mainline grade, and electrical interface adhere to the specifications. Track position, and module construction within the "set" may be of the builder's choosing.

Module Height: Floor to top of roadbed = 40"

Clearances: Vertical from top of rail = 3" minimum Horizontal from center of track = 1" minimum. This applies, but is not limited to, all bridges, buildings, signals, and tunnels.

Track: **Mainlines:**
 Centerline of outer main track is measured 5" from front face of front frame member, *not from fascia board*. Centerline of inner main track is 7" from front face of front frame member.
 Preferred track, ATLAS Code 100 Flex-Track. ATLAS Code 83 may be used, however if the builder uses Code 83, the Connecting track must use ATLAS 551 transition joiners.

Local Track:
 Centerline of local track is measured 9" from front face of front frame member, *not from fascia board*.
 Preferred track, ATLAS Code 83 Flex-Track. ATLAS Code 100 may be used, however if the builder uses Code 100, the Connecting track must use ATLAS 551 transition joiners.

Additional Track:
 Any track in addition to the mainlines and local track may be of the builders choosing.

Track ends:
 Both main lines and local track must end 4 1/2" from each end of the module.

Connecting track:
 Each module is connected by a standard 9" piece of commercial straight track, Code 100 *Atlas Snap Track* for mainlines, and a standard 9" piece of commercial straight track, Code 83 *Atlas Snap Track* for the local track. If your module contains non-standard track on the mainlines or local track, you must provide connector tracks with ATLAS 551 transition joiners.

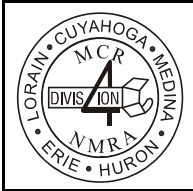

MODULAR LAYOUT SYSTEM SPECIFICATIONS

DIVISION 4, MID CENTRAL REGION, NMRA

DATA SHEET	DIV4-1.1
PAGE	2 OF 3
REVISION	0
DATE	May 25, 2007

- Grade:** Mainline track grade is 0%
- Turnouts:** Preferred turnouts are *PECO Medium Insulfrog* (approximately a #6) or equal. Hand laid turnouts in the mainline are discouraged.
- Diamonds:** Commercial diamonds are recommended in mainline track.
- Crossovers:** Must be insulated at crossover track to electrically isolate the two mainlines or the inside mainline and local track.
- Roadbed:** Roadbed can be any material that is 3/16" thick.
- Ballast:** Main line ballast must be. *Smith and Son* Gray Limestone #40
- Paint:**
- Backboard:**
 Sherwin-Williams SW1787 "Baby Blues"
 or
The Home Depot Behr Interior Flat Wall 1050 UP White Quart
- | Pigment | Oz | 48ths. | 96ths. |
|---------------|----|--------|--------|
| Lamp Black | 0 | 1 | 1 |
| D Thalo Green | 0 | 3 | 0 |
| E Thalo Blue | 0 | 8 | 0 |
- The back, inward facing side, of all backboards must be painted flat black and stenciled with the name of the module in white.
 The ends and fascia, of all modules must be painted flat black.
- Highway Crossings:** Roadway material must be at least 1/32" below top of rail.
- Uncouplers:** None allowed in mainline or local track.
- Scenery:** Scenery shall end at least one inch from the edge of the module so as not to conflict with the adjacent modules.
- Signals:** All block signal and grade crossing flasher systems shall be independently powered not using track power.
 Block detection using current detection must use detectors that do not connect directly to track power. Use either current transformer detectors or opto-isolated detectors. When using current transformer detectors , the module or selected block must be isolated with an insulated track joiners.

General Electrical Specifications

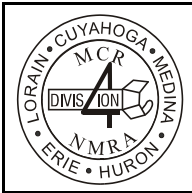

MODULAR LAYOUT SYSTEM SPECIFICATIONS

DIVISION 4, MID CENTRAL REGION, NMRA

DATA SHEET	DIV4-1.1
PAGE	3 OF 3
REVISION	0
DATE	May 25, 2007

Connectors:

All track connectors shall be *Anderson Powerpole®* PP15 or PP30

The following are *Anderson Powerpole®* part numbers:

15A Contacts (16 - 20 AWG)	1332	
30A Contacts (12 - 16 AWG)	1331	Recommended
Red Housing	1327	Outside Main
Green Housing	1327G5	Return Loop
Black Housing	1327G6	All
White Housing	1327G7	AC
Blue Housing	1327G8	Local Track
Yellow Housing	1327G16	Inside Main
Orange Housing	1327G17	Accessory DCC

Auxiliary connectors, not used for main module power, may be any suitable connector of the builders choosing, *Anderson Powerpole®* connectors are recommended.

Track Power:

Track power shall be DCC (Digital Command Control).

Accessory AC:

AC accessory power 16-18 VAC of suitable current, (5-10 A) shall be provided for powering accessories such as, switch machines, structure lighting, signal systems, etc.

Wire:

All interconnecting wire shall be 16 AWG stranded minimum. This includes wire for the Outer Mainline, Inner Mainline, Local Track and Accessory AC

SECTION 1

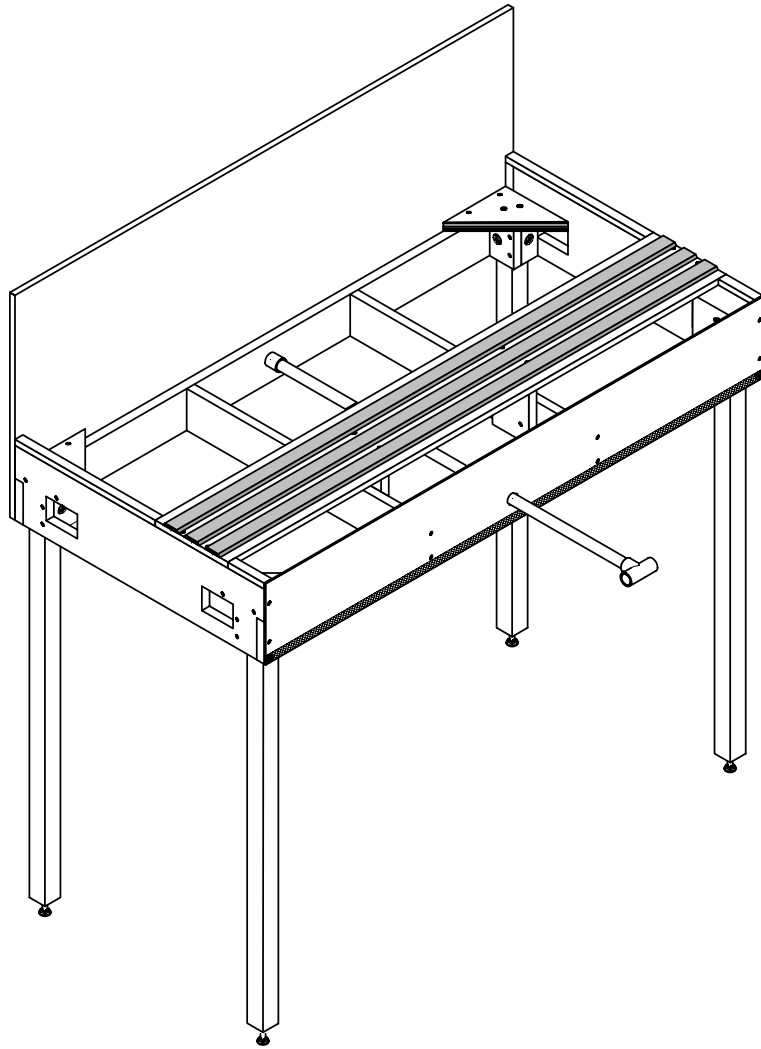

STRAIGHT MODULE



MODULAR LAYOUT SYSTEM SPECIFICATIONS

DIVISION 4, MID CENTRAL REGION, NMRA

DATA SHEET	DIV4-2.1
PAGE	1 OF 2
REVISION	0A
DATE	May 25, 2007

PARTS LIST - HO STRAIGHT MODULE

Item	Quan	Description
1	2	3/4" Plywood Connecting Ends
2	1	1 X 4 X 48" Pine Front Ledger
3	1	1 X 4 X 48" Pine Rear Ledger
4	2	1 X 4 X 22 1/2 " Pine Cross Brace
5	4	Gusset
6	4	Leg Pocket Assemblies - See Appendix "A"
7	4	Leg Assemblies - See Appendix "A"
8	1	18 3/4"X 48" 1/2" Plywood Backboard
9	1	Crowd Barrier (Plastic Pipe and Tee)- 1 /2" PVC
10	1	½ " PVC Plastic pipe cap for Crowd Barrier
11	1	6 3/4"X 48" X 1/8" Tempered Masonite Fascia
12	4 ft	1 /2" <i>Velcro</i> Loops (Skirt Attachment)
13	2	2 1/2" X 1 3/8" C-Clamps
14	as req	#8X1 1/4" FH Wood Screws (Roadbed, Risers, Backboard)
15	as req	#8X1 1/2" FH Wood Screws (frame)
16	as req	#6X3/4" FH Wood Screws (fascia)
17	as req	#6X3/4" PH Sheet Metal Screws (Pipe Cap)
18	as req	#6X1/2" PH Sheet Metal Screws (Cable Clamps, <i>Velcro</i> Cable Ties)
19	as req	#6 X 5/8" Fender Washers (<i>Velcro</i> Skirt Attachment, Cable Ties)
20	as req	5/8" - 18 Wire Nails (Roadbed)
21	as req	<i>ATLAS</i> Track Nails
22	as req	Rail Joiners
23	2	<i>Velcro</i> Cable Ties
24	12 ft	<i>Homa-Bed</i> , Cork, or Milled Wood Roadbed
25	6 ft.	<i>ATLAS</i> Code 100 Nickel-Silver Flex Track
26	4	1 ½ in <i>ATLAS</i> Code 100 Snap Track - Catalog No. 825
27	2	9" <i>ATLAS</i> Code 100 Snap Track - Mainline Joiner Tracks
27	3 ft	<i>ATLAS</i> Code 83 Nickel-Silver Flex Track

	MODULAR LAYOUT SYSTEM SPECIFICATIONS DIVISION 4, MID CENTRAL REGION, NMRA	DATA SHEET	DIV4-2.1	
	PAGE	2	OF	2
	REVISION	0A		
	DATE	May 25, 2007		

Item	Quan	Description
28	2	1 ½ in ATLAS Code 83 Snap Track - Catalog No. 523
29	1	9" ATLAS Code 83 Snap Track - Mainline Joiner Tracks
Additional Parts - Open Top Module		
41	1	1/2" Plywood Sub-Roadbed 7" X 48" (Open Top Module with Local Track)
42	2	1X4 X 6" Pine Risers (Not Used with Full-top Module)
43	1	15/32" X 3/4" X 48" Filler Strip (Cut into 4 Pcs See Drawing)
44	as req	1" - 18 Wire Nails (Filler Strip)

Additional Parts - Full Top Module

51	1	1/2" Plywood Sub-Roadbed 24" X 48" (Full Top Module)
52	2	1 ½ X 22 in Pine Roadbed Support
53	4	1 1/2 X 6 in Pine Risers

The following items are for the wiring harness. A pre-wired harness is available from Division 4.
Contact the Division 4 Module Chairman for price and delivery information

61	10	Anderson <i>Powerpole</i> Housing - Black P/N 1327G6
62	2	Anderson <i>Powerpole</i> Housing - Red P/N 1327
63	2	Anderson <i>Powerpole</i> Housing - Yellow P/N 1327G16
64	2	Anderson <i>Powerpole</i> Housing - Blue P/N 1327G8
65	2	Anderson <i>Powerpole</i> Housing - Orange P/N 1327G17
66	2	Anderson <i>Powerpole</i> Housing - White P/N 1327G7
67	20	Anderson <i>Powerpole</i> Contacts 30A for 12-16 AWG Wire P/N 1331
68	30 ft	2 Conductor 16 AWG Stranded Cable
69	15 ft	#18 Stranded Hookup Wire
70	1	Terminal Block - 12 Positions - <i>MOLEX</i> 39100-1012 or equal
71	4	5/16" Cable Clamps
72	as req	#18 Solid Copper Wire - Track Feed
73	3	#4 X 3/4 PH Sheet Metal Screws (Terminal Block)



MODULAR LAYOUT SYSTEM SPECIFICATIONS

DIVISION 4, MID CENTRAL REGION, NMRA

DATA SHEET DIV4_3.1

PAGE 1 OF 16

REVISION 0A

DATE MAY 25, 2007

OPEN TOP STRAIGHT MODULE

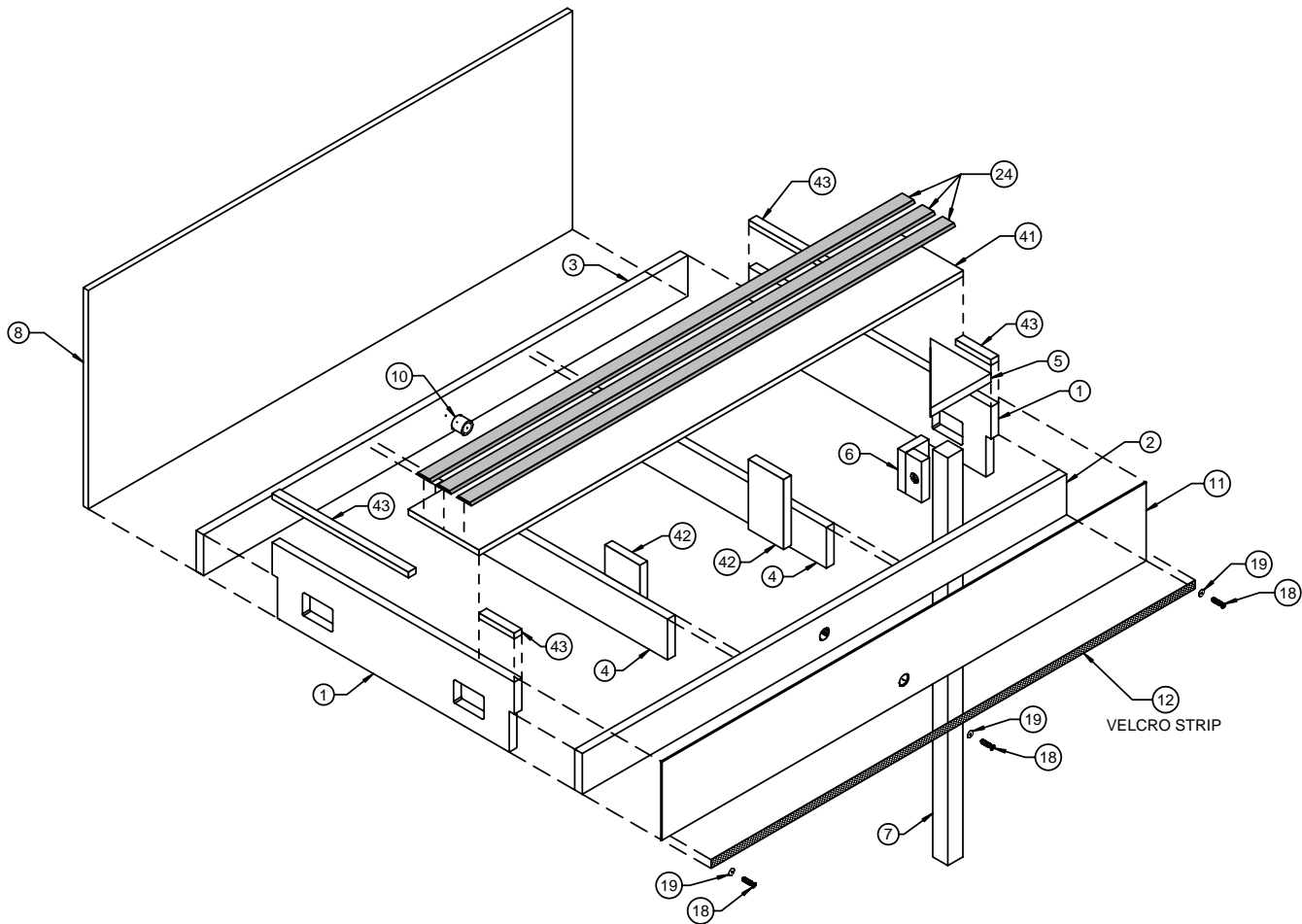



MODULAR LAYOUT SYSTEM SPECIFICATIONS

DIVISION 4, MID CENTRAL REGION, NMRA

DATA SHEET	DIV4_3.1
PAGE	2 OF 16
REVISION	0A
DATE	MAY 25, 2007

FULL TOP STRAIGHT MODULE

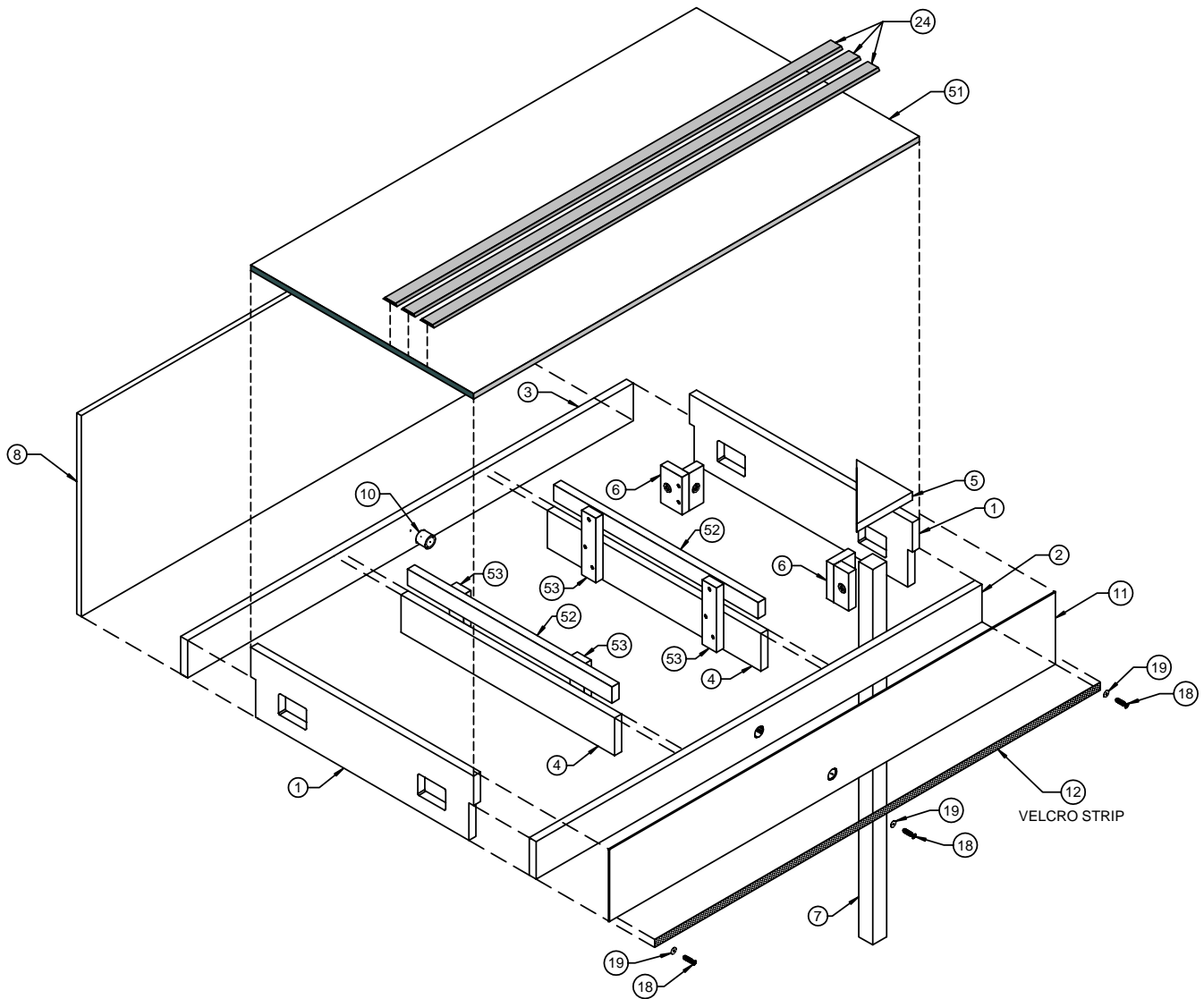



MODULAR LAYOUT SYSTEM SPECIFICATIONS

DIVISION 4, MID CENTRAL REGION, NMRA

DATA SHEET DIV4_3.1

PAGE 3 OF 16

REVISION 0A

DATE MAY 25, 2007

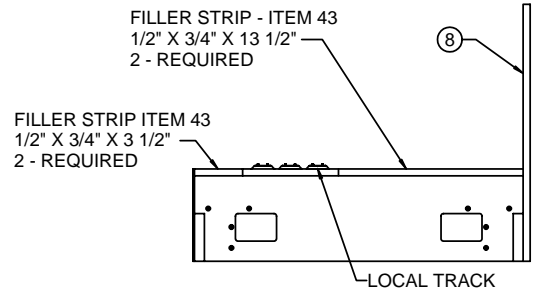
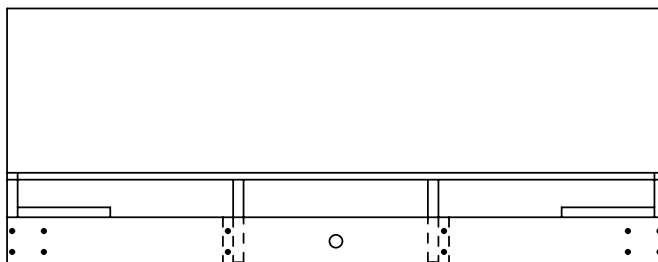
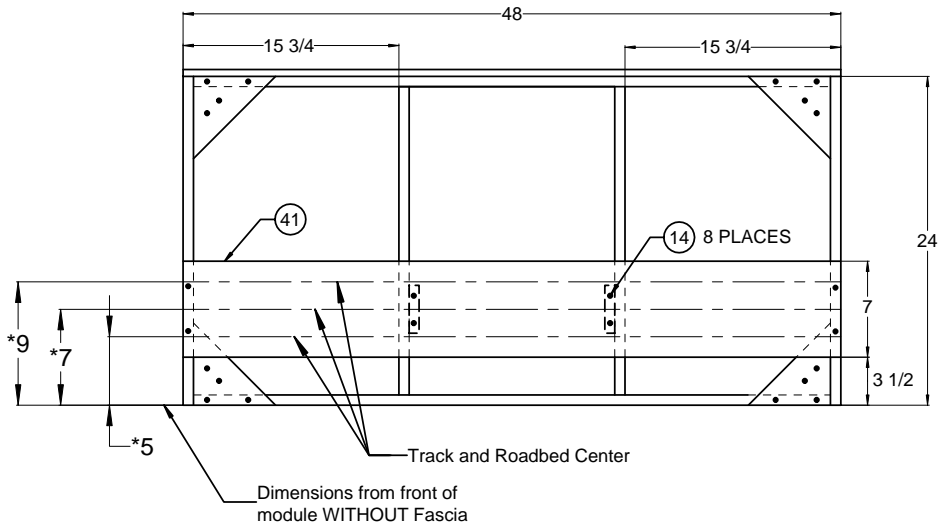

Dimensions shown with (*) are required

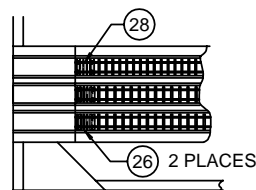
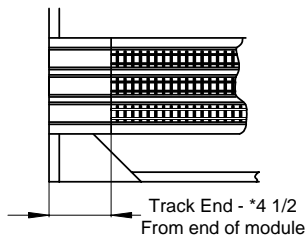

Suggested method for track ends on modules
Use Atlas 1 1/2" Snap Track sections for end of track, no undercutting is required, and replacement is simple in case the track ends get damaged.



MODULAR LAYOUT SYSTEM SPECIFICATIONS

DIVISION 4, MID CENTRAL REGION, NMRA

DATA SHEET DIV4_3.1

PAGE 4 OF 16

REVISION 0A

DATE MAY 25,2007

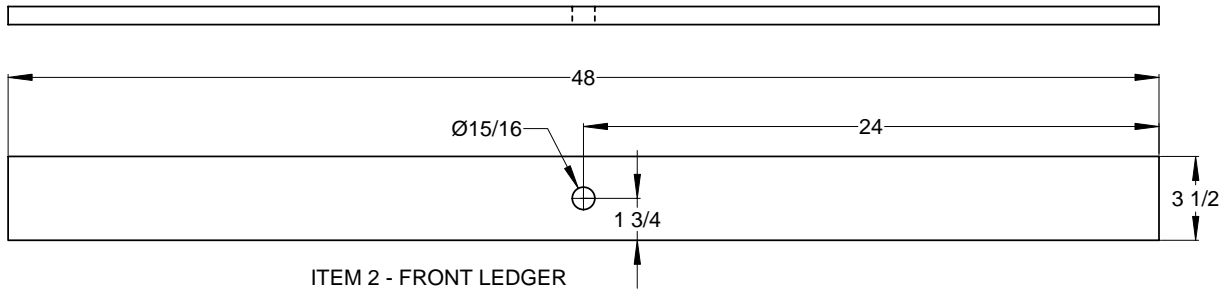

ITEM 2 - FRONT LEDGER
1 REQUIRED
MATERIAL - PINE 1X4

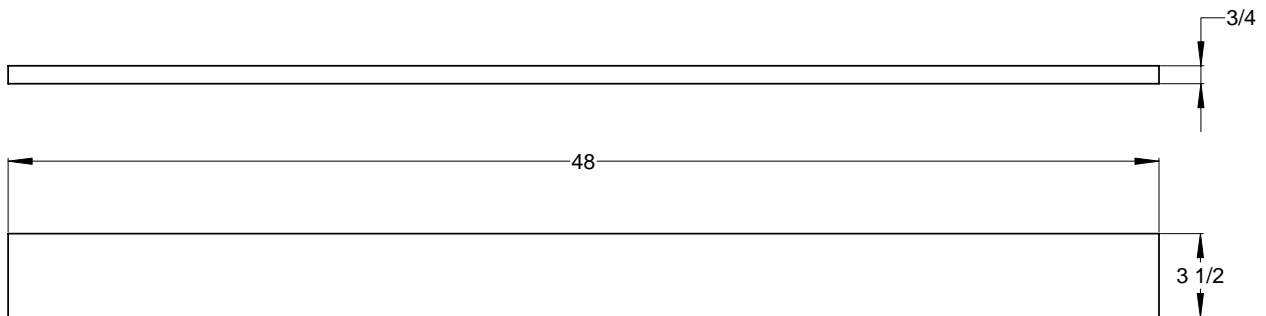

ITEM 3 - REAR LEDGER
1 REQUIRED
MATERIAL - PINE 1X4

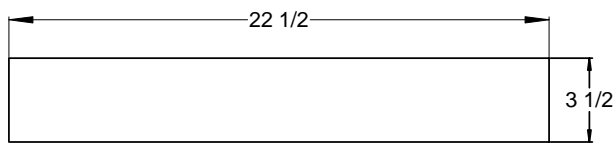

ITEM 4 - CROSS BRACE
2 REQUIRED
MATERIAL - PINE 1X4

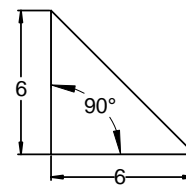

ITEM 5 - GUSSET
(4) REQUIRED
MATERIAL - PLYWOOD 3/4"

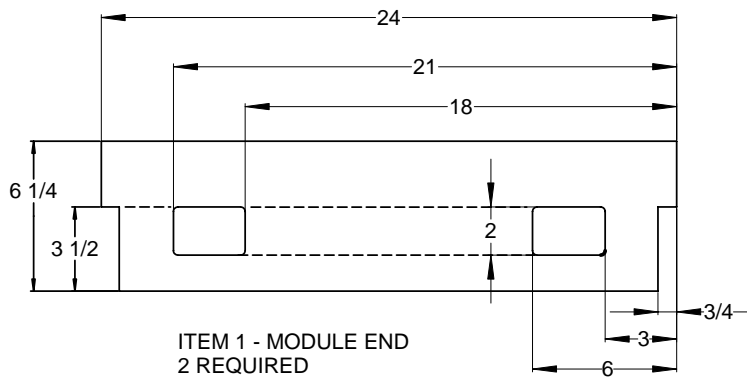

ITEM 1 - MODULE END
2 REQUIRED
MATERIAL - PLYWOOD, 3/4"



MODULAR LAYOUT SYSTEM SPECIFICATIONS

DIVISION 4, MID CENTRAL REGION, NMRA

DATA SHEET DIV4_3.1

PAGE 5 OF 16

REVISION 0A

DATE MAY 25,2007

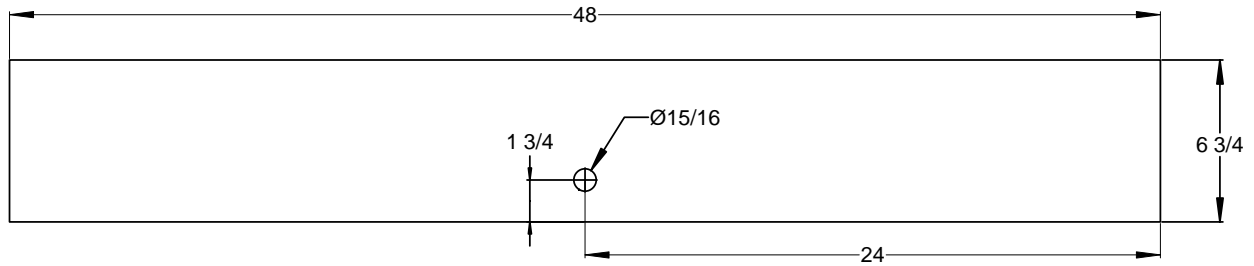

ITEM 11 - FASCIA
1 REQUIRED
MATERIAL - 1/8" TEMPERED MASONITE

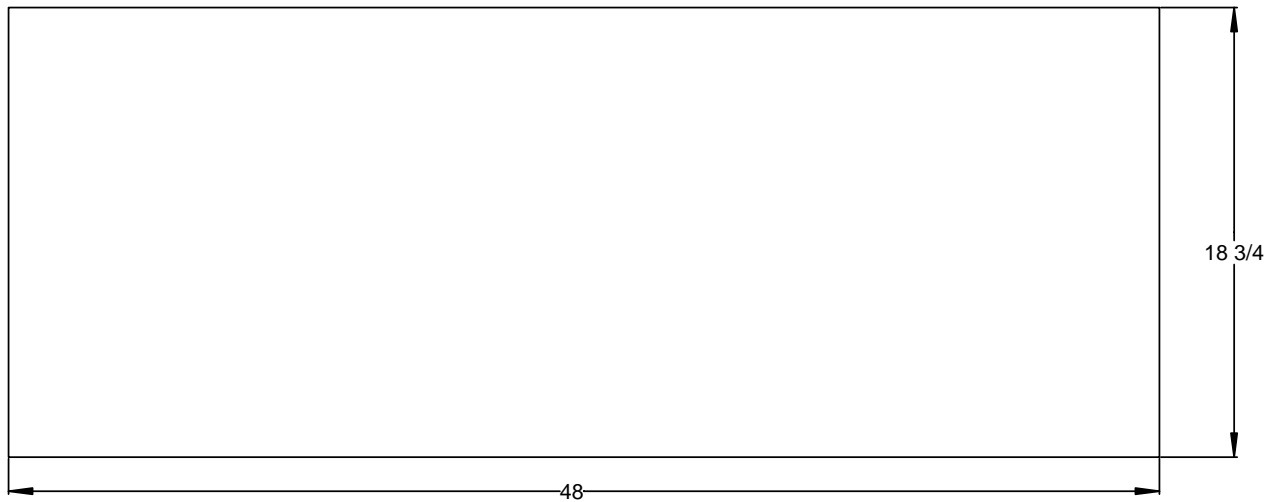

ITEM 8 - BACKBOARD
1 REQUIRED
MATERIAL - 1/2" PLYWOOD

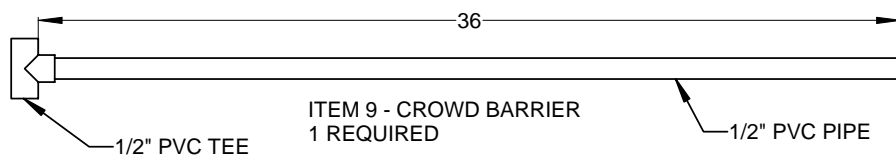

ITEM 9 - CROWD BARRIER
1 REQUIRED

1/2" PVC TEE

1/2" PVC PIPE



MODULAR LAYOUT SYSTEM SPECIFICATIONS

DIVISION 4, MID CENTRAL REGION, NMRA

DATA SHEET DIV4_3.1

PAGE 6 OF 16

REVISION 0A

DATE MAY 25,2007

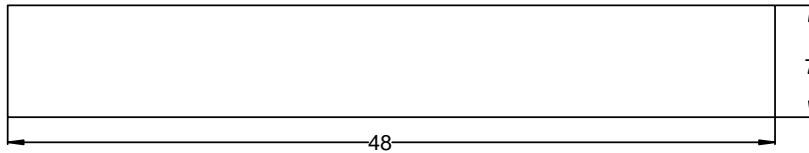

ITEM 41 - SUB ROADBED
1 REQUIRED
MATERIAL - 1/2" PLYWOOD

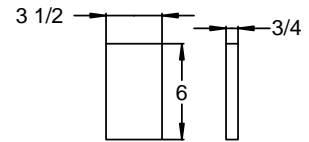

ITEM 42 - RISER
2 REQUIRED
MATERIAL - PINE 1X4

OPEN TOP



ITEM 51 - SUB ROADBED
1 REQUIRED
MATERIAL - 1/2 PLYWOOD

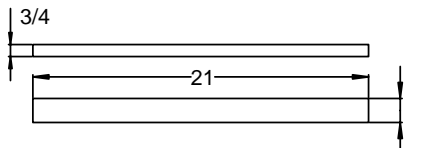

ITEM 52 - ROADBED SUPPORT
2 REQUIRED
MATERIAL - PINE

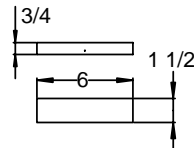

ITEM 53 - RISER
4 REQUIRED
MATERIAL - PINE

FULL TOP



MODULAR LAYOUT SYSTEM SPECIFICATIONS

DIVISION 4, MID CENTRAL REGION, NMRA

DATA SHEET DIV4_3.1

PAGE 7 OF 16

REVISION 0A

DATE MAY 25,2007

SUGGESTED METHOD OF ASSEMBLY

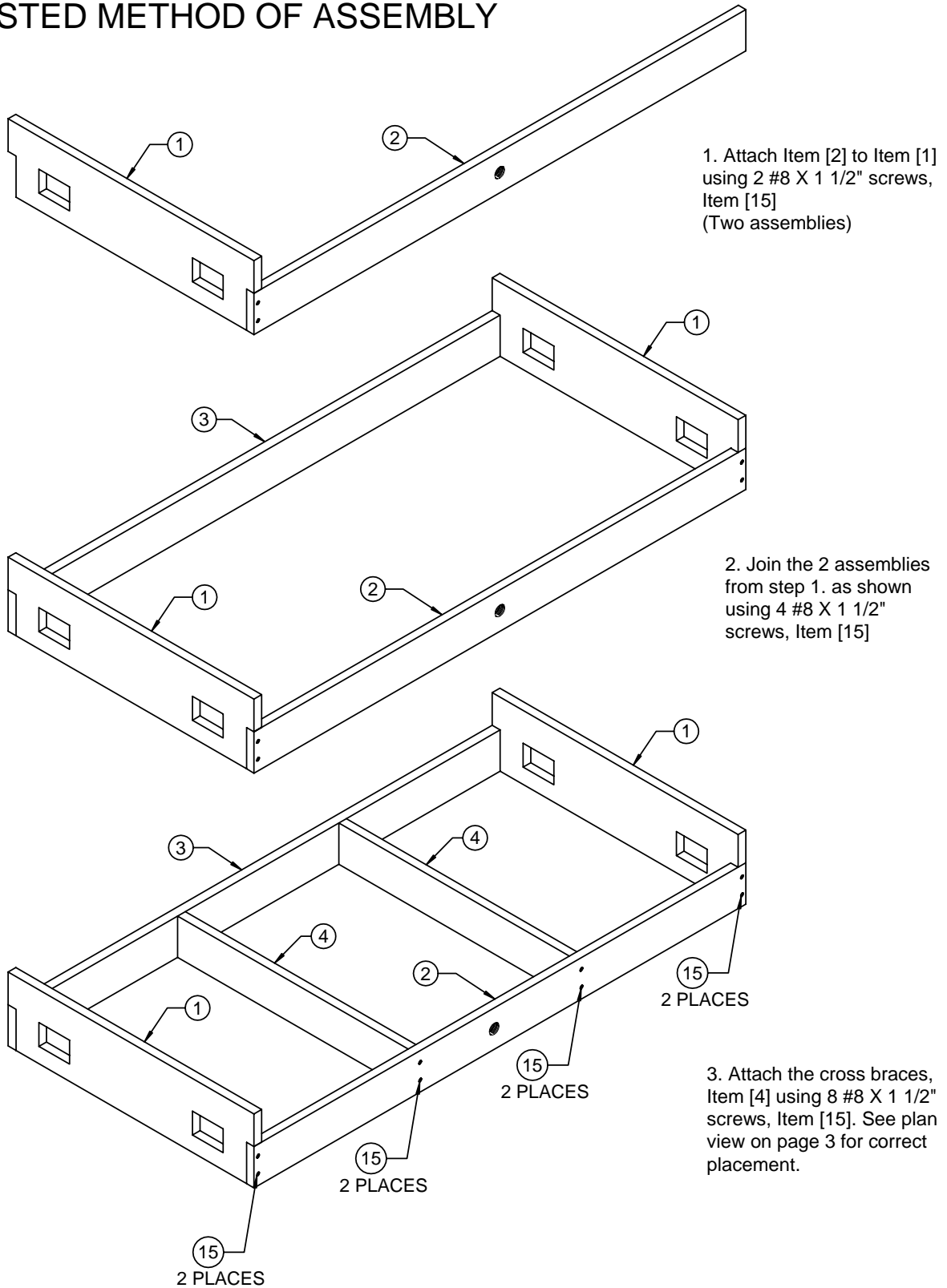



MODULAR LAYOUT SYSTEM SPECIFICATIONS

DIVISION 4, MID CENTRAL REGION, NMRA

DATA SHEET DIV4_3.1

PAGE 8 OF 16

REVISION 0A

DATE MAY 25,2007

SUGGESTED METHOD OF ASSEMBLY

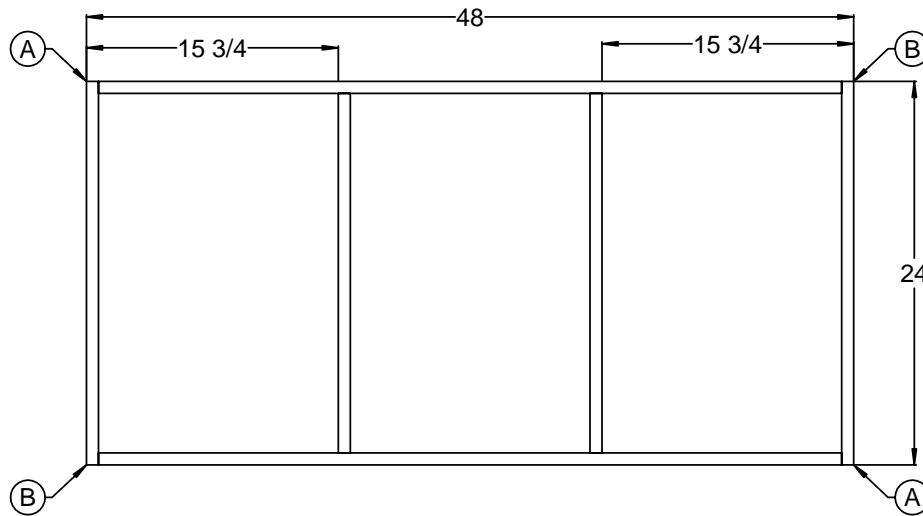

Note:
Before installing Gussets Item 5, the dimensions A-A and B-B must be equal, approx. 53 11/16 in.

Attach Gussets, Item [5] using #8X1-1/2 screws, item [15]. Make sure that dimensions A-A and B-B are equal, and module frame is flat.

After securing gussets attach leg pocket assemblies, Item [7] using #8X1-1/2 screws, item [15]. Refer to sheet 9 for leg pocket assembly detail.

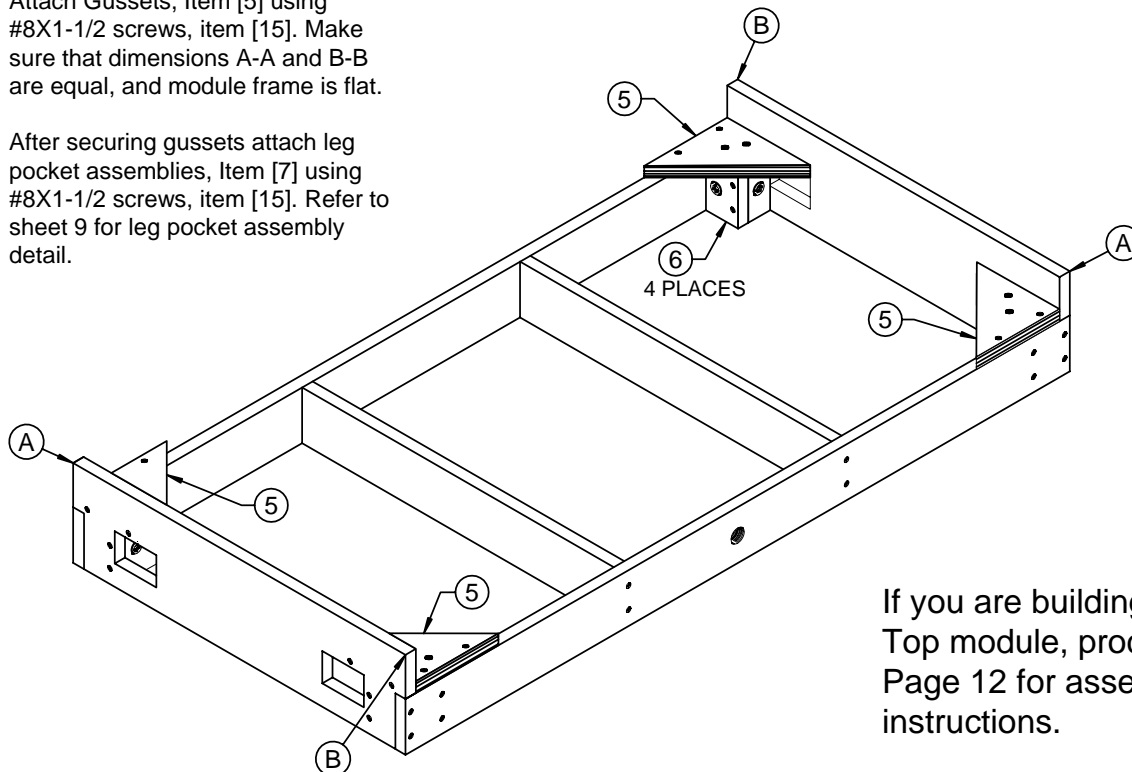

If you are building a Full Top module, proceed to Page 12 for assembly instructions.



MODULAR LAYOUT SYSTEM SPECIFICATIONS

DIVISION 4, MID CENTRAL REGION, NMRA

DATA SHEET DIV4_3.1

PAGE 9 OF 16

REVISION 0A

DATE MAY 25, 2007

SUGGESTED METHOD OF ASSEMBLY

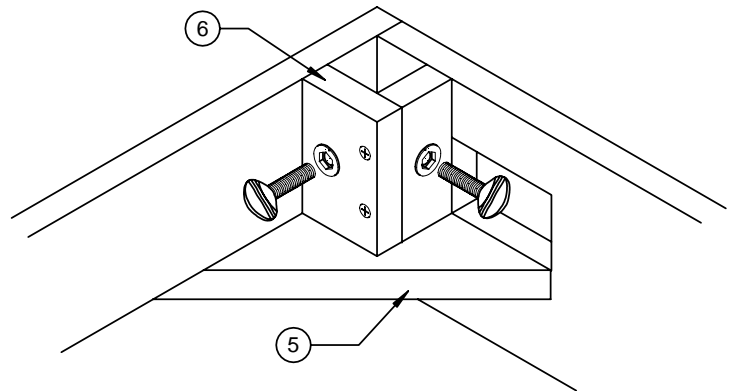
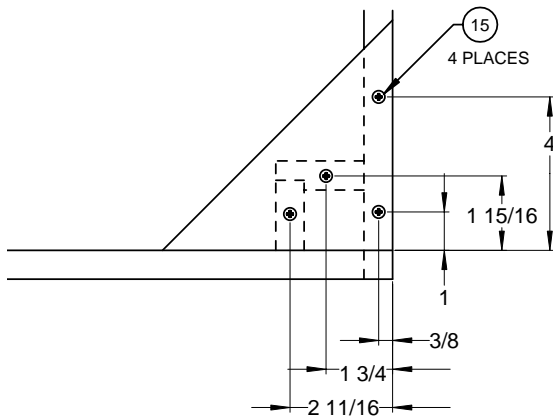
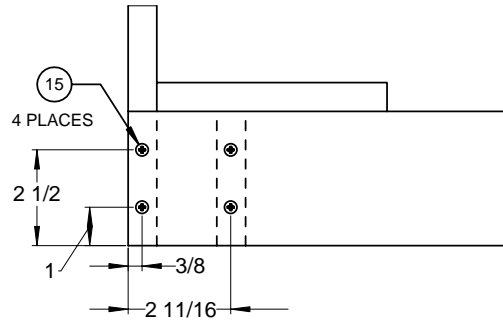
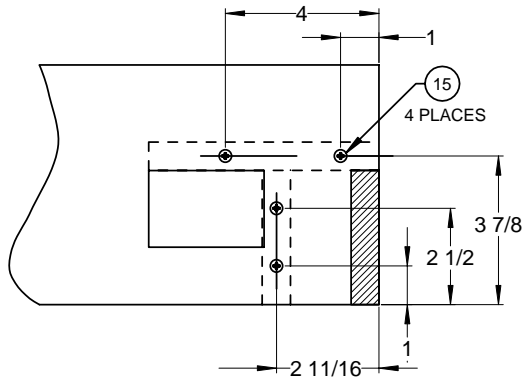

ASSEMBLY DETAIL - LEG POCKETS

Note:

The dimensions for screw placement are approximate, shown for illustration only.



MODULAR LAYOUT SYSTEM SPECIFICATIONS

DIVISION 4, MID CENTRAL REGION, NMRA

DATA SHEET DIV4_3.1

PAGE 10 OF 16

REVISION 0A

DATE MAY 25, 2007

SUGGESTED METHOD OF ASSEMBLY

Note:

Before fastening risers, attach sub-roadbed, Item 41, to module ends using 4 #8 X 1 1/4" screws, item 14. Make sure that the sub-roadbed is flat. Clamp risers, item 42 to crossmembers then secure risers to cross-members with #8 X 1 1/4" screws, Item 14

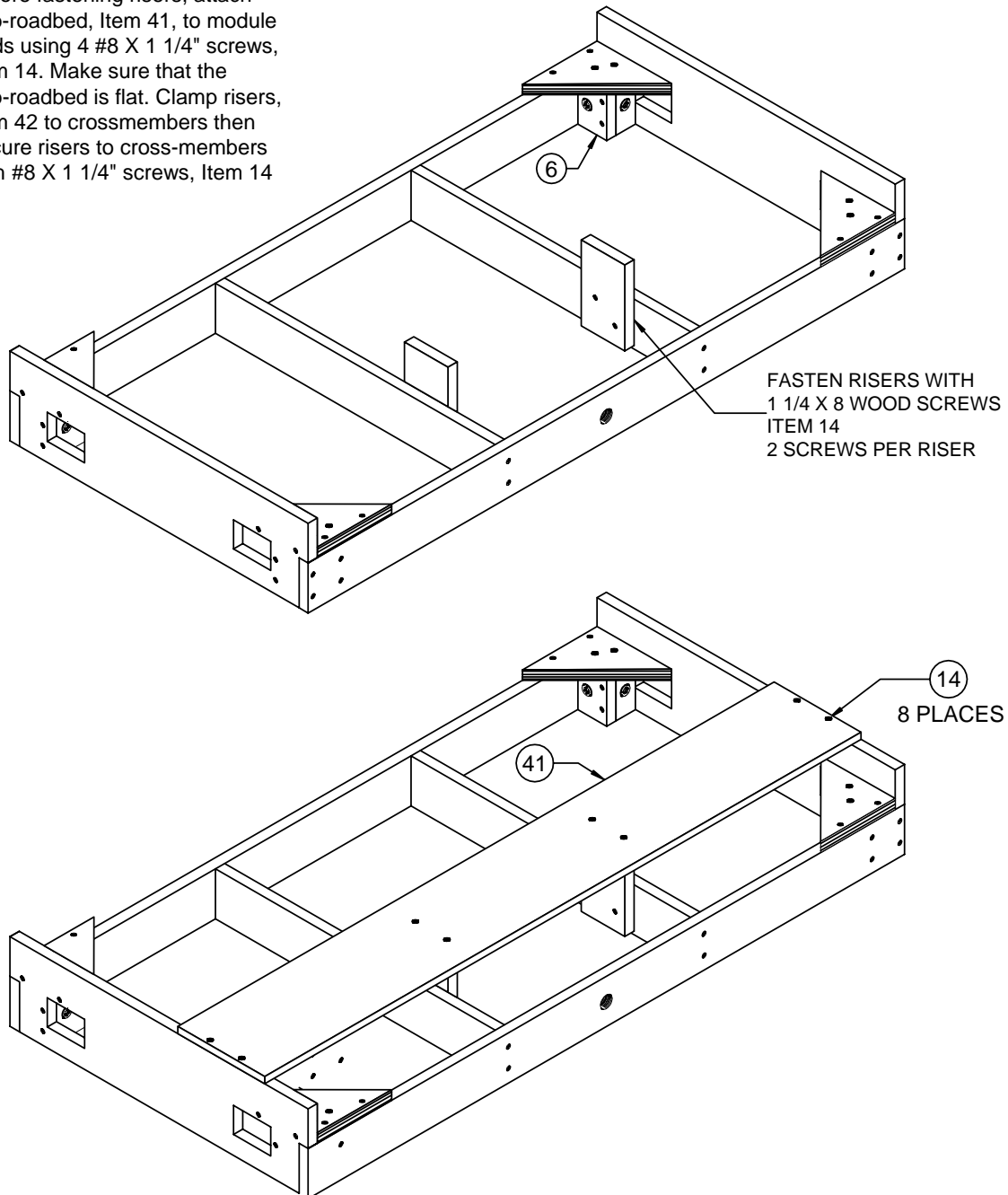



MODULAR LAYOUT SYSTEM SPECIFICATIONS

DIVISION 4, MID CENTRAL REGION, NMRA

DATA SHEET DIV4_3.1

PAGE 11 OF 16

REVISION 0A

DATE MAY 25, 2007

SUGGESTED METHOD OF ASSEMBLY

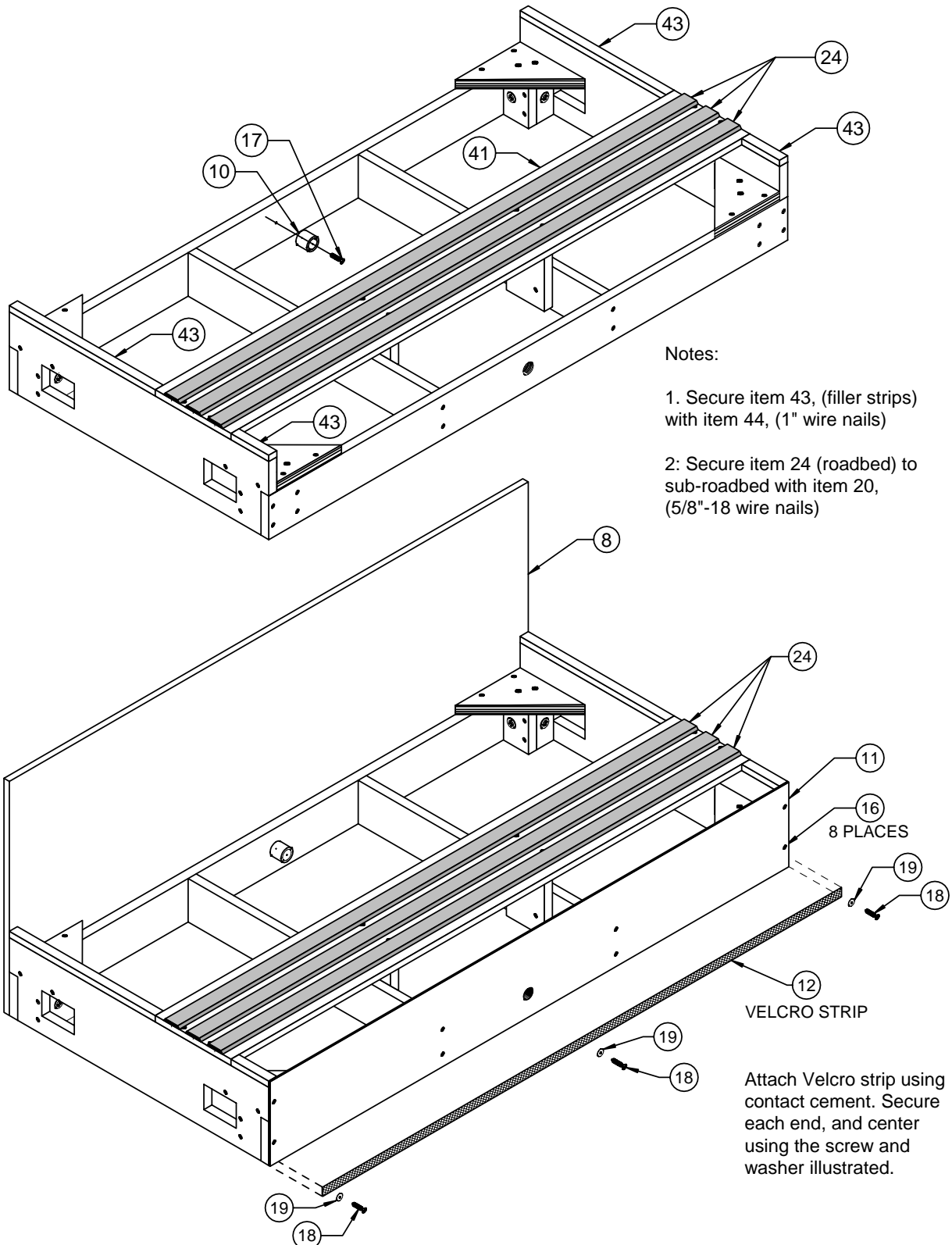



MODULAR LAYOUT SYSTEM SPECIFICATIONS

DIVISION 4, MID CENTRAL REGION, NMRA

DATA SHEET DIV4_3.1

PAGE 12 OF 16

REVISION 0A

DATE MAY 25, 2007

SUGGESTED METHOD OF ASSEMBLY

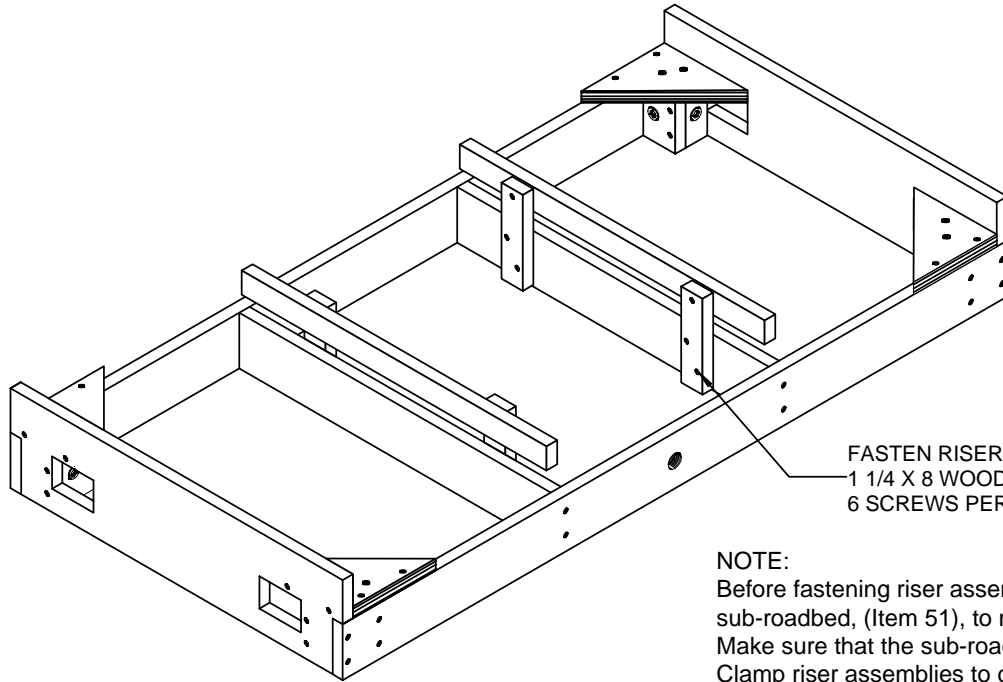

FASTEN RISER ASSEMBLIES WITH
1 1/4 X 8 WOOD SCREWS ITEM 14
6 SCREWS PER RISER ASSEMBLY

NOTE:

Before fastening riser assemblies, attach sub-roadbed, (Item 51), to module ends. Make sure that the sub-roadbed is straight. Clamp riser assemblies to crossmembers, check top of sub-roadbed with a straightedge. Make sure the sub-roadbed is flat, then secure riser assemblies to crossmembers with #8 X 1 1/4" screws, (Item 14)

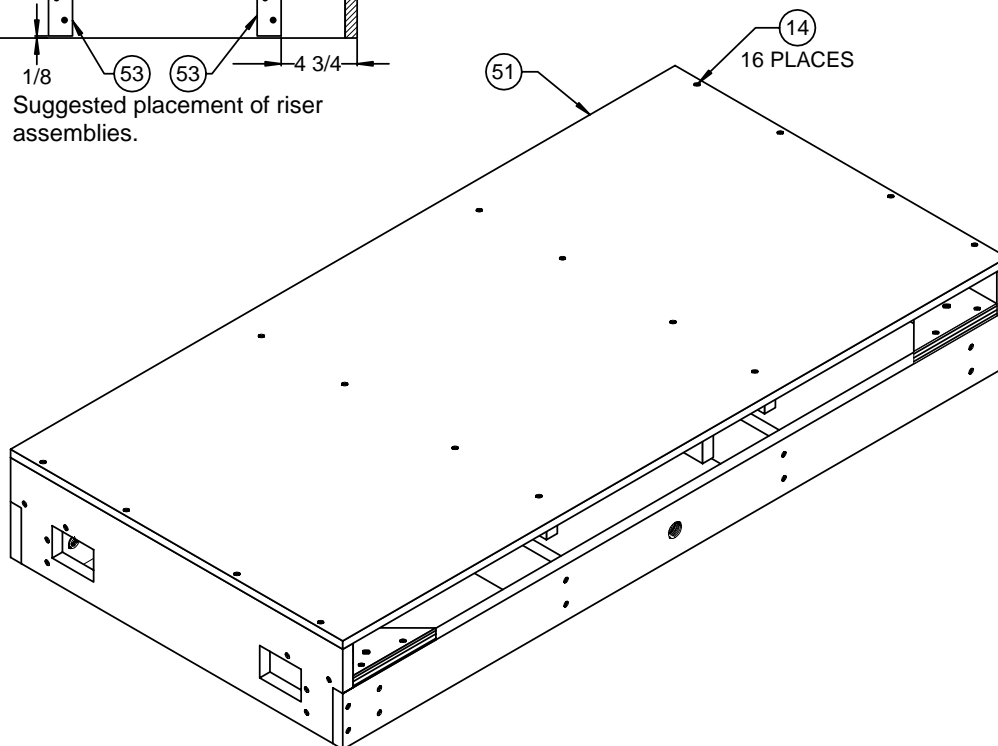
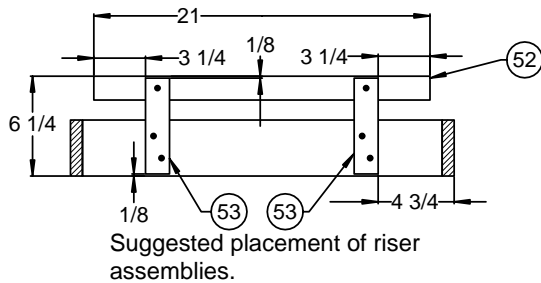

(14)
16 PLACES



MODULAR LAYOUT SYSTEM SPECIFICATIONS

DIVISION 4, MID CENTRAL REGION, NMRA

DATA SHEET DIV4_3.1

PAGE 13 OF 16

REVISION 0A

DATE MAY 25, 2007

SUGGESTED METHOD OF ASSEMBLY

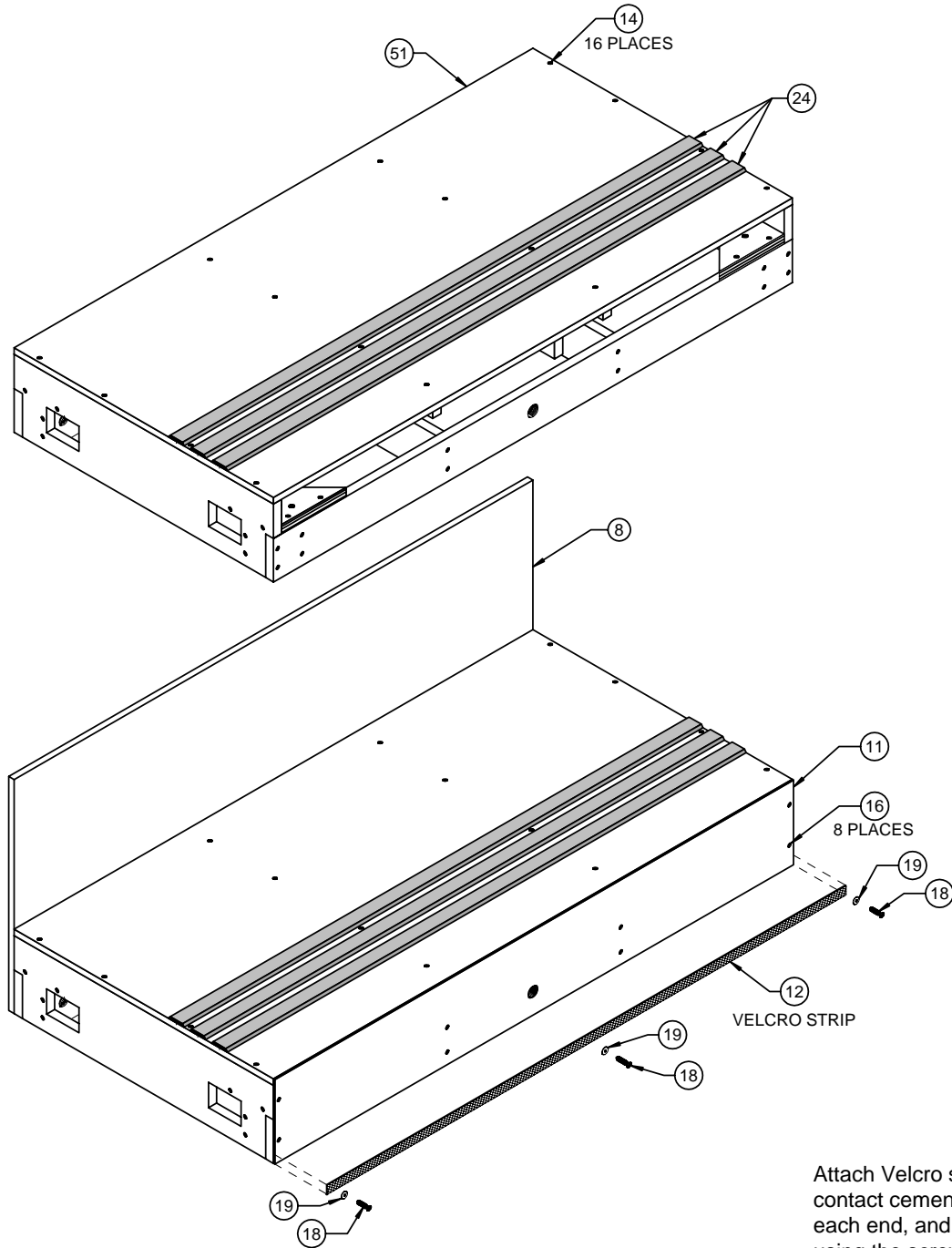

Attach Velcro strip using contact cement. Secure each end, and center using the screw and washer illustrated.



MODULAR LAYOUT SYSTEM SPECIFICATIONS

DIVISION 4, MID CENTRAL REGION, NMRA

DATA SHEET DIV4_3.1

PAGE 14 OF 16

REVISION 0A

DATE MAY 25, 2007

SUGGESTED METHOD OF ASSEMBLY

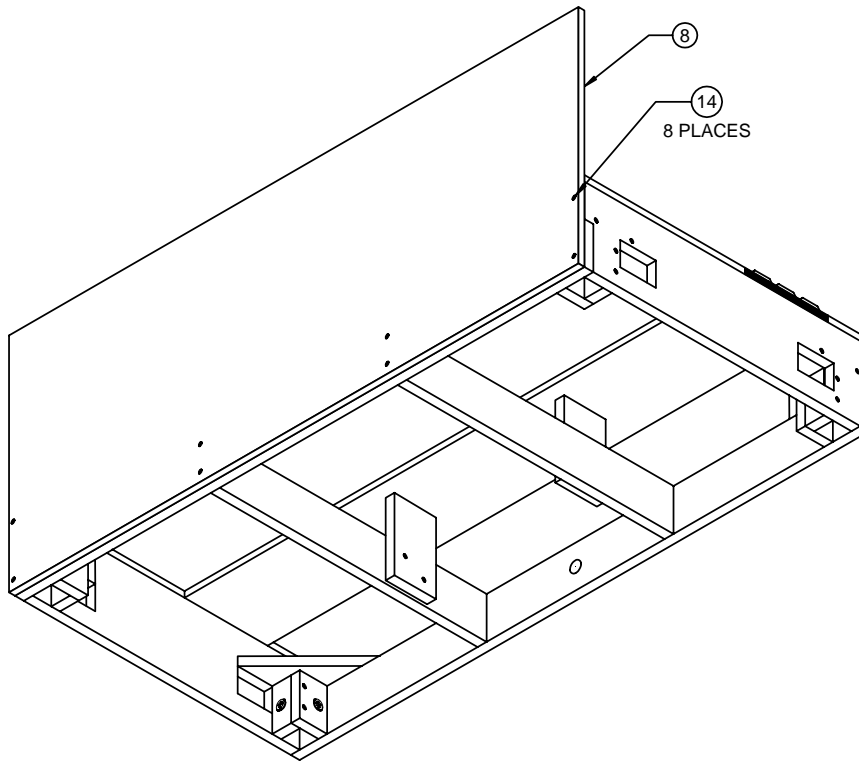

OPEN TOP
MODULE

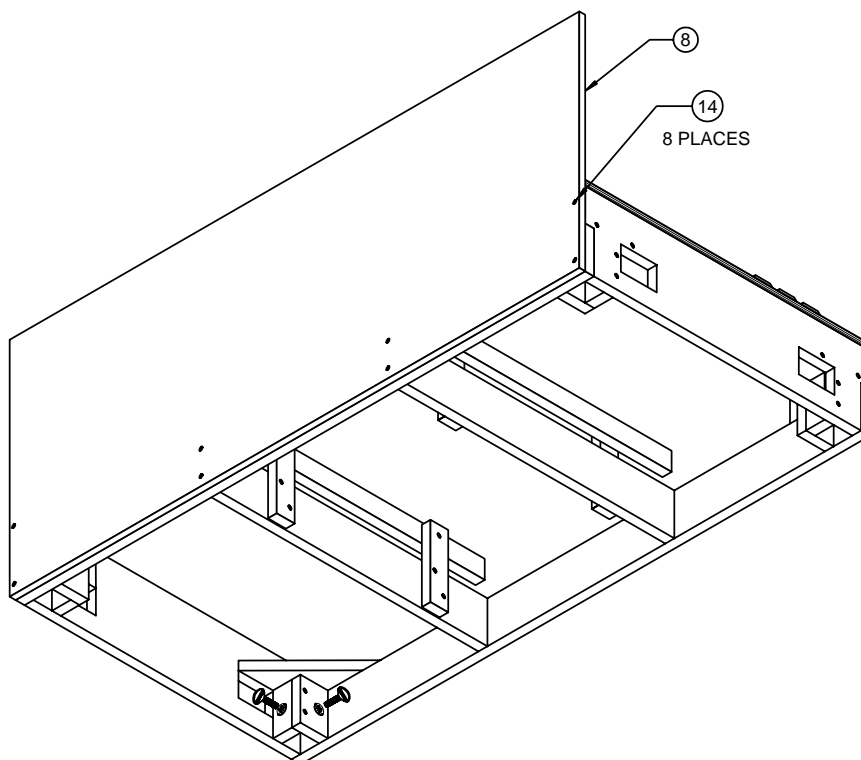

FULL TOP
MODULE



MODULAR LAYOUT SYSTEM SPECIFICATIONS

DIVISION 4, MID CENTRAL REGION, NMRA

DATA SHEET DIV4_3.1

PAGE 15 OF 16

REVISION 0A

DATE MAY 25, 2007

BASIC WIRING DIAGRAM INCLUDING ACCESSORY DCC

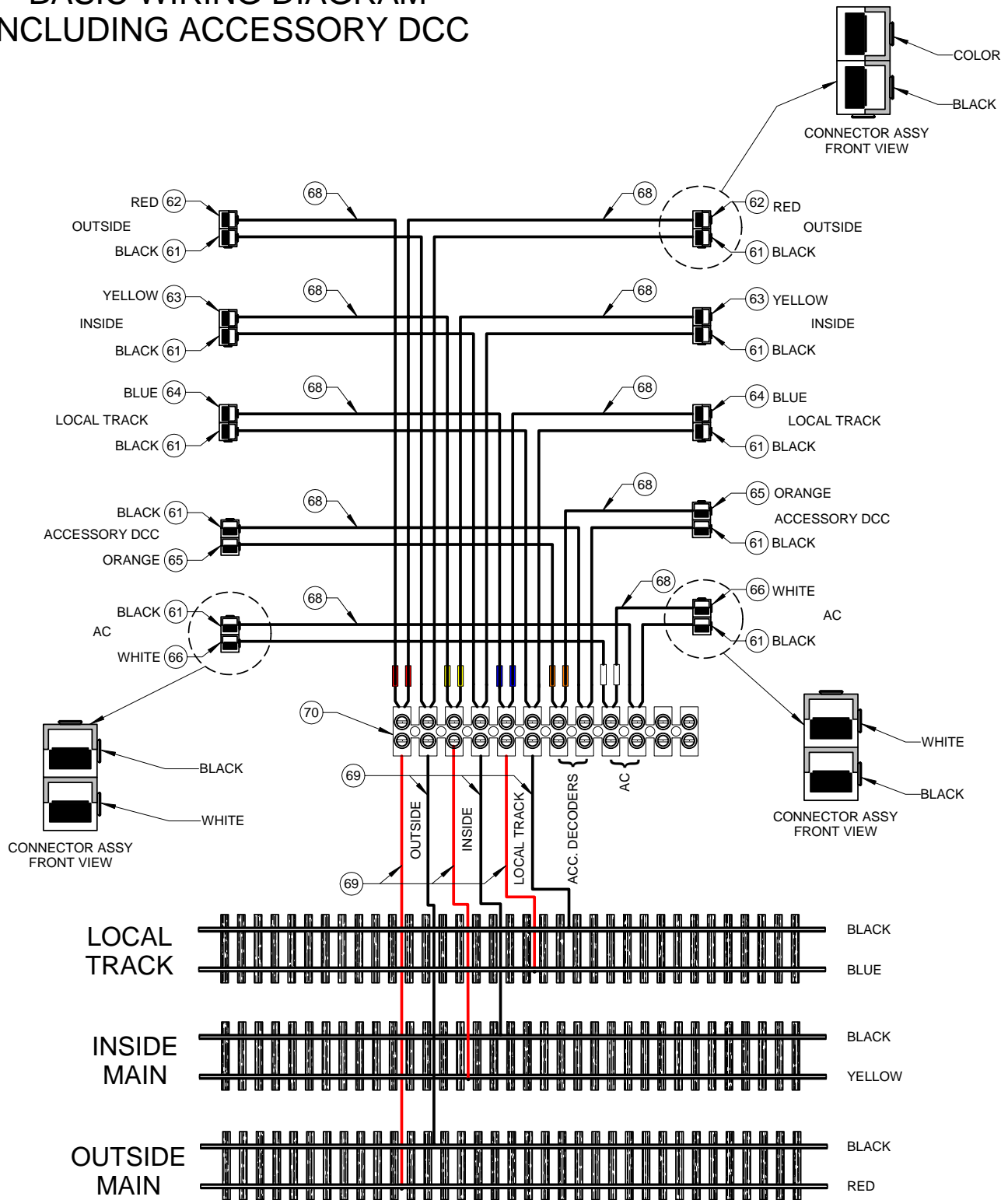

FRONT OF MODULE - VIEWING SIDE



STRAIGHT MODULE KIT ASSEMBLY INSTRUCTIONS

DIVISION 4, MID CENTRAL REGION, NMRA

DATA SHEET DIV4_3.1

PAGE 16 OF 16

REVISION 0A

DATE MAY 25, 2007

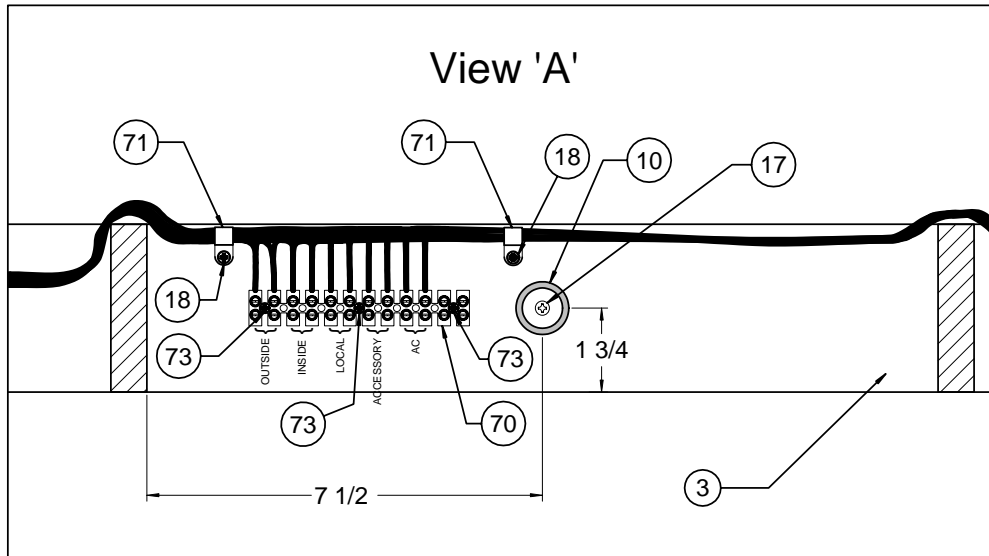
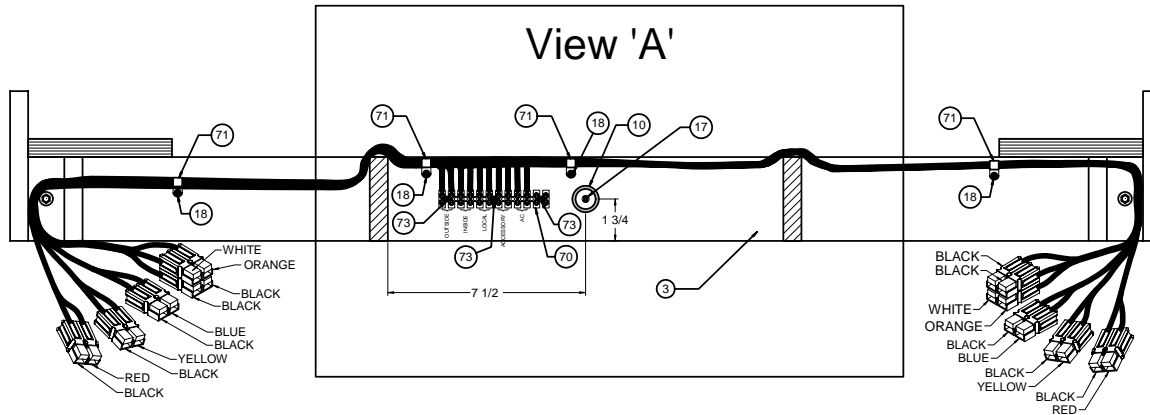

Suggested placement of Velcro Cable Tie

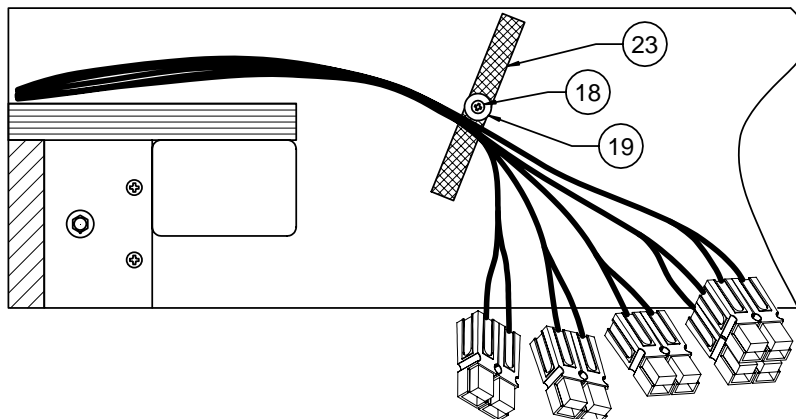

SECTION 2

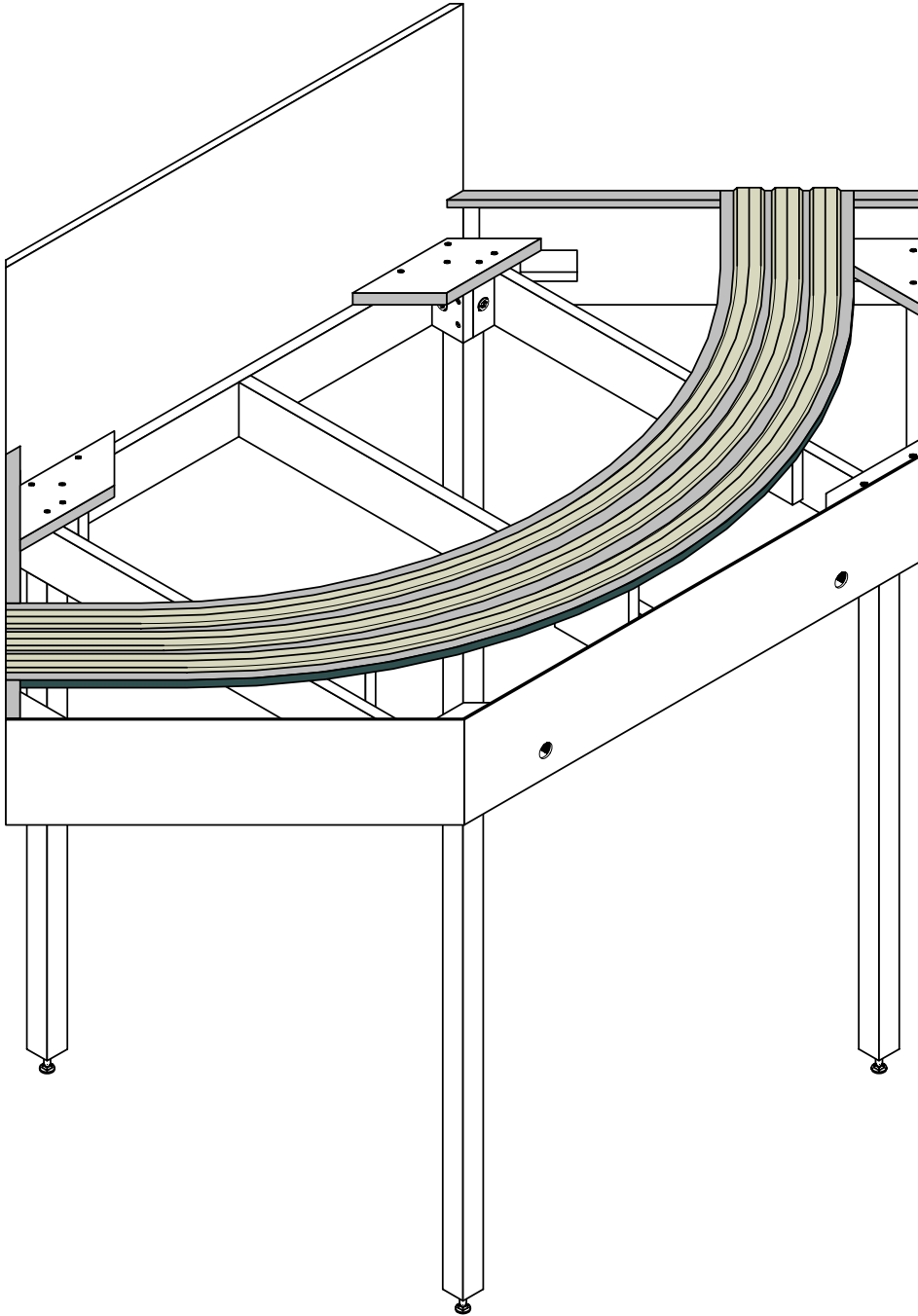

CORNERS

To be released
at a later date

SECTION 3

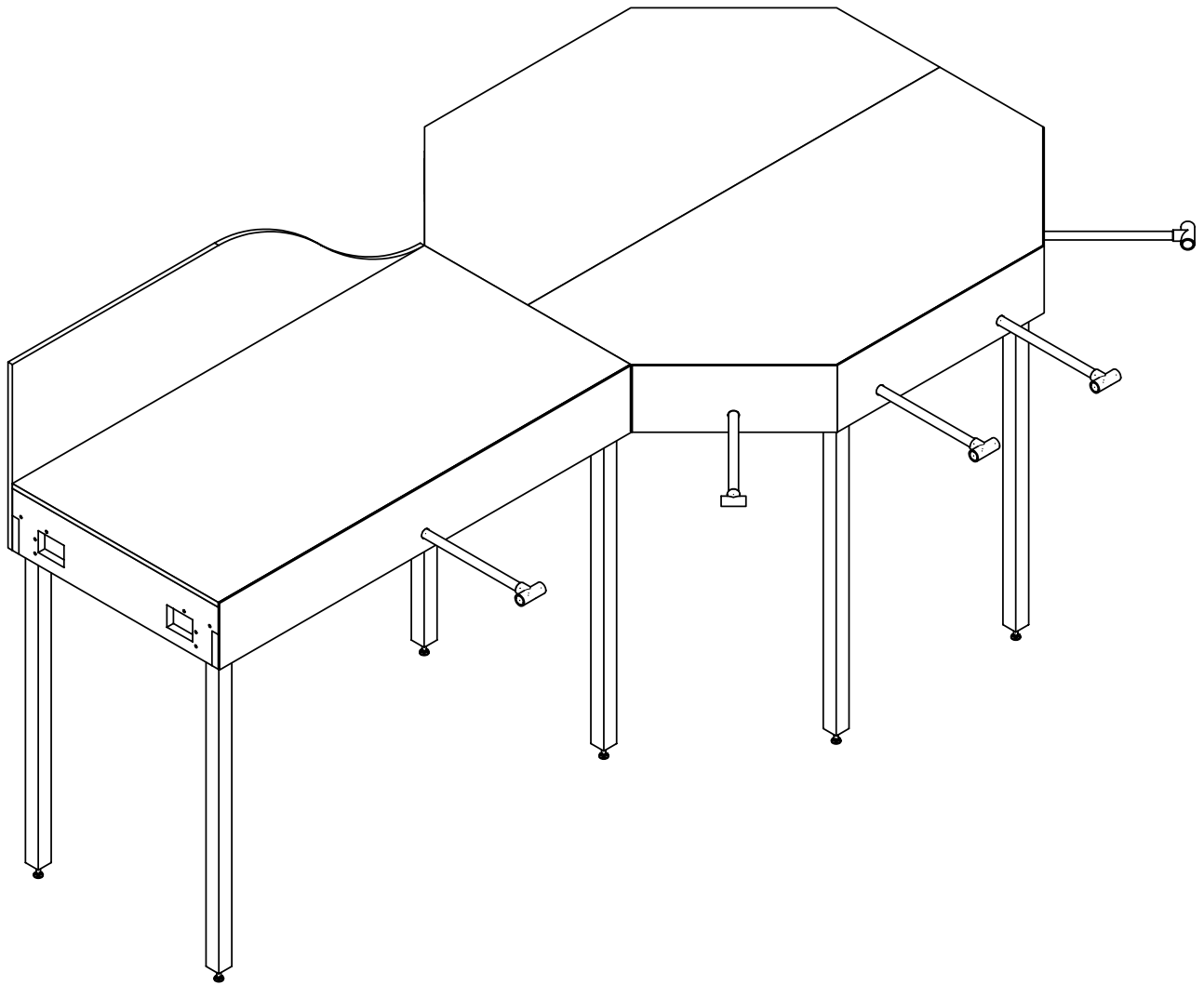

RETURN LOOP

To be released
at a later date

APPENDIX

A

	MODULAR LAYOUT SYSTEM SPECIFICATIONS DIVISION 4, MID CENTRAL REGION, NMRA	DATA SHEET	DIV4_4.1		
		PAGE	1	OF	1
		REVISION	0A		
		DATE	May 25, 2007		

APPENDIX "A" - LEG POCKET ASSEMBLIES PARTS LIST

Item	Quan	Description
1	1	Leg pocket 'A' (See assembly dwg)
2	1	Leg Pocket 'B' (See assembly dwg)
3	2	5/16-18 X1 1/2" Thumbscrews for Leg Pockets (See assembly dwg)
4	1	2X2 (1 1/2" X 1 1/2") X 35" Leg (See assembly dwg)
5	1	3/8-16 Threaded Inserts for Legs and Leg Pockets (See assembly dwg) McMaster-Carr Catalog No. 92105A430
6	2	5/16-18 Threaded Inserts for Legs and Leg Pockets (See assembly dwg) McMaster-Carr Catalog No. 92105A410
7	1	3/8-16 X 4" Full Thread Carriage Bolts - Leg adjusting bolts (See assembly dwg)
8	2	#8 X1 1/4" FH Wood Screws



MODULAR LAYOUT SYSTEM SPECIFICATIONS

DIVISION 4, MID CENTRAL REGION, NMRA

DATA SHEET DIV4_3.1

PAGE 1 OF 1

REVISION 0A

DATE MAY 25,2007

LEGS AND LEG POCKETS

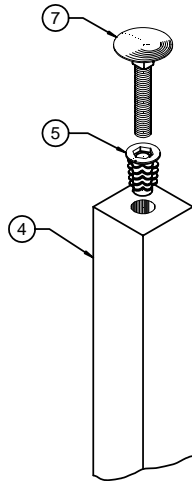
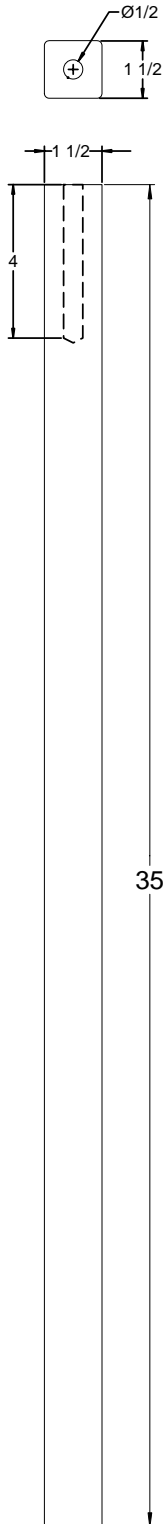

LEG ADJUSTER
ASSEMBLY

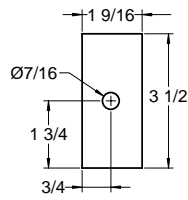

LEG POCKET A
ITEM 1

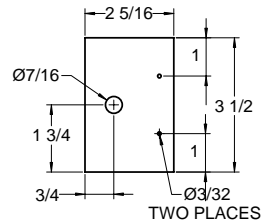

LEG POCKET B
ITEM 2

Step 1: Cut the two pieces
shown above from
3/4" Plywood

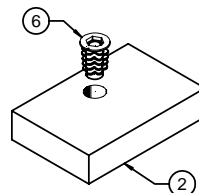
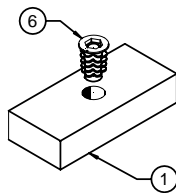

Step 2: Install 5/16 - 18 threaded insert
in each piece as shown.
2 inserts total. (ITEM 6)

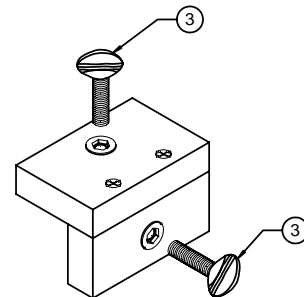

Step 3: Assemble the two pieces as shown
using 2 - 1 1/4" X 8 screws (Item 8)
and glue.

APPENDIX

B



DCC COMMAND BUS

To be released
at a later date